

Characterised control valve, Internal thread
2-way, 3-way

- For open and closed cold and warm water systems
- For modulating water-side control of air handling units and heating systems
- Air bubble-tight



Type overview

Type	Valve []	DN []	kvs [m³/h]	Rp ["]	PN []	n(gl) []	Sv min. []
R2025-25-S2	2-way	25	25	1	40	3.2	100
R2032-25-S3	2-way	32	25	1 1/4	25	3.2	100
R2050-58-S4	2-way	50	58	2	25	3.2	100
R2050-70-S4	2-way	50	70	2	25	3.2	100
R2065-150-S4	2-way	65	150	2 1/2	25	3.2	100
R2080-150-S4	2-way	80	150	3	25	3.2	100
R3032-25-S3	3-way	32	25	1 1/4	25	3.2	100
R3040-40-S4	3-way	40	40	1 1/2	25	3.2	100
R3050-58-S4	3-way	50	58	2	25	3.2	100

Technical data

Functional data	Media	
	Media	Cold and warm water, water with glycol up to max. 50% vol.
	Medium temperature	-10...120°C DN25...50 -18...100°C DN65...80
	Medium temperature note	The allowed media temperature can be limited, depending on the type of actuator. Limitations can be found in the respective data sheets of the actuators.
	Closing pressure Δp_s	1400kPa DN25...50 700kPa DN65...80
	Differential pressure Δp_{max}	350kPa DN25...50 200kPa DN65...80
	Differential pressure note	200kPa for low-noise operation
	Leakage rate	2-way 3-way
		Leakage rate A, air bubble-tight (EN 12266-1) Control path A - AB: Leakage rate A, air bubble-tight (EN 12266-1), Bypass B - AB: Leakage class I (EN 1349 and EN 60534-4) approx. 1...2% of the kvs value
	Flow rate	3-way
		Bypass B - AB: 70% of kvs value
	Flow characteristic	2-way 3-way
		Equal percentage (VDI/ VDE 2178), optimised in the opening range Control path A - AB: equal percentage (VDI/ VDE 2178, optimised in the opening range, Bypass B - AB: linear (VDI/ VDE 2178)
	Pipe connectors	Internal thread according to ISO 7-1
	Angle of rotation	90°
	Installation position	Upright to horizontal (in relation to the stem)
	Maintenance	Maintenance-free
Materials	Housing	Brass body nickel-plated
	Closing element	Stainless steel
	Stem	Stainless steel
	Stem seal	O-ring EPDM
	Valve seat	PTFE, O-ring EPDM
	Characterising disc	TEFZEL R3050-58-S4: Stainless steel R2025-25-S2: no characterizing disc

Sizing diagram for Characterised Control Valves

Legend

ΔP_{max}
 Maximum permitted pressure difference for long service life across control path A-AB referred to the whole range of opening.
 ΔP_{max} for low-noise operation
 ΔP_{v100}
 pressure difference with Ball Valve fully open
 \dot{V}_{100}
 Nominal flow rate at ΔP_{v100}

Formula for Kvs

$$Kvs = \sqrt{\frac{\dot{V}_{100}}{\frac{\Delta P_{v100}}{100}}}$$

\dot{V}_{100} [m³/h]
 ΔP_{v100} [kPa]

Definition of Close-off pressure

ΔPs
 Differential pressure at which the actuator can still seal the valve tightly allowing for the appropriate leakage rate.

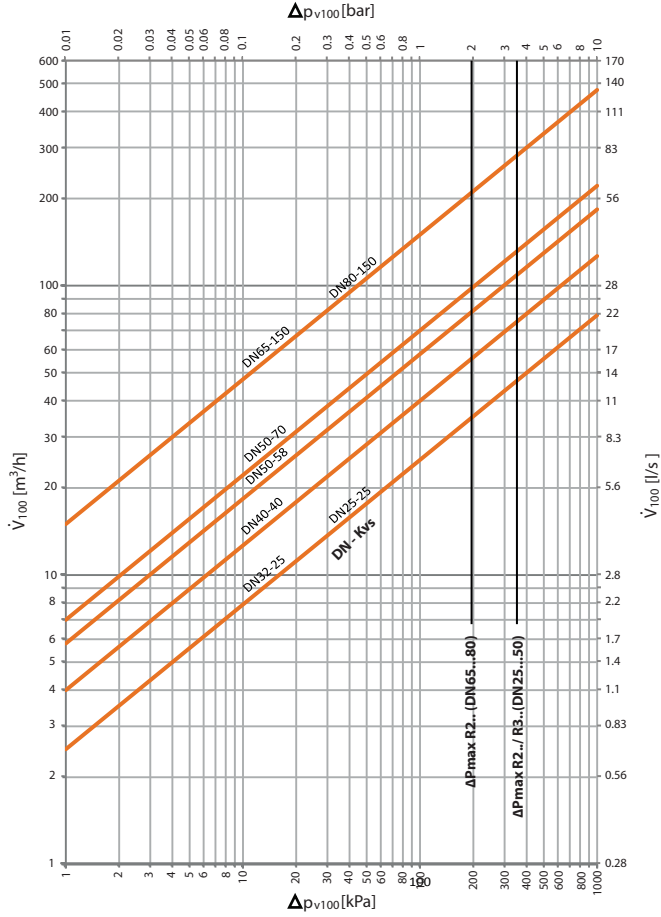

Actuator selection

Connection	Internal thread						
	25	25	40	58	70	150	150
Kvs[m ³ /h]	25	25	40	58	70	150	150
DN[mm]	25	32	40	50	50	65	80
2-way	R2025-25-S2	R2032-25-S3	-	R2050-58-S4	R2050-70-S4	R2065-150-S4	R2080-150-S4
3-way	-	R3032-25-S3	R3040-40-S4	R3050-58-S4	-	-	-

Modulating	DC (0)2...10V (-SR) or DC 0.5...10V (-SZ)		
	LR24A-SR(-SZ)	NR24A-SR(-SZ)	SR24A-SR(-SZ)
Fail-Safe	LRF24A-SR	NRF24A-SR	SRF24A-SR
Fast Running	LRQ24A-SR	NRQ24A-SR	SRQ24A-SR

Safety notes



- The valve has been designed for use in stationary heating, ventilation and air-conditioning systems and is not allowed to be used outside the specified field of application, especially in aircraft or in any other airborne means of transport.
- Only authorised specialists may carry out installation. All applicable legal or institutional installation regulations must be complied during installation.
- The valve does not contain any parts that can be replaced or repaired by the user.
- The valve may not be disposed of as household refuse. All locally valid regulations and requirements must be observed.
- When determining the flow rate characteristic of controlled devices, the recognised directives must be observed.

Product features

- Mode of operation** The characterised control valve is adjusted by a rotary actuator. The actuator is controlled by a commercially available modulating or 3-point control system and moves the ball of the valve – the throttling device – to the position dictated by the positioning signal. Open the characterised control valve counterclockwise and close it clockwise.
- Flow characteristic** Equal percentage flow control is ensured by the integrated characterising disc.

Accessories

	Description	Type
Mechanical accessories	Pipe connector to ballvalves DN 25 Rp 1"	ZR2325
	Pipe connector to ballvalves DN 32 Rp 1 1/4"	ZR2332
	Pipe connector to ballvalves DN 40 Rp 1 1/2"	ZR2340
	Pipe connector to ballvalves DN 50 Rp 2"	ZR2350

Installation notes

Recommended installation positions The ball valve can be installed upright to horizontal. The ball valve may not be installed in a hanging position, i.e. with the stem pointing downwards.

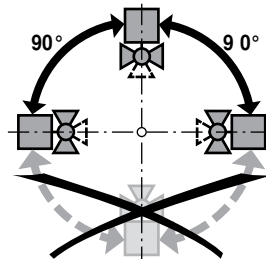

Water quality requirements The water quality requirements specified in VDI 2035 must be adhered to. Belimo valves are regulating devices. For the valves to function correctly in the long term, they must be kept free from particle debris (e.g. welding beads during installation work). The installation of suitable strainer is recommended.

Maintenance Ball valves and rotary actuators are maintenance-free. Before any kind of service work is carried out on the actuator, it is essential to isolate the rotary actuator from the power supply (by unplugging the electrical cable). Any pumps in the part of the piping system concerned must also be switched off and the appropriate slide valves closed (allow everything to cool down first if necessary and reduce the system pressure to ambient pressure level). The system must not be returned to service until the ball valve and the rotary actuator have been properly reassembled in accordance with the instructions and the pipeline has been refilled in the proper manner.

Flow direction The direction of flow, specified by an arrow on the housing, is to be complied with, since otherwise the ball valve could become damaged. Please ensure that the ball is in the correct position (marking on the spindle).

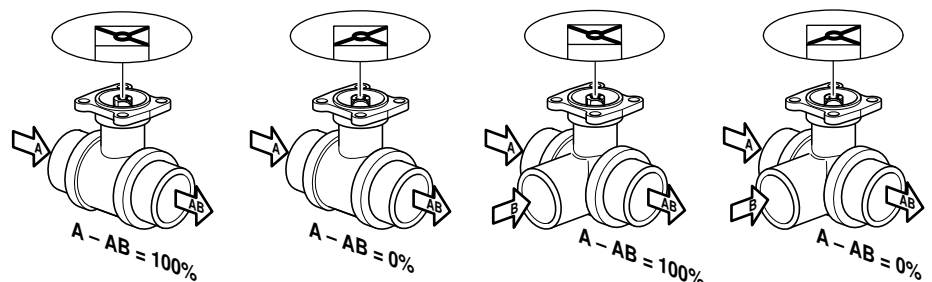

Dimensions [mm]

Dimensional drawings

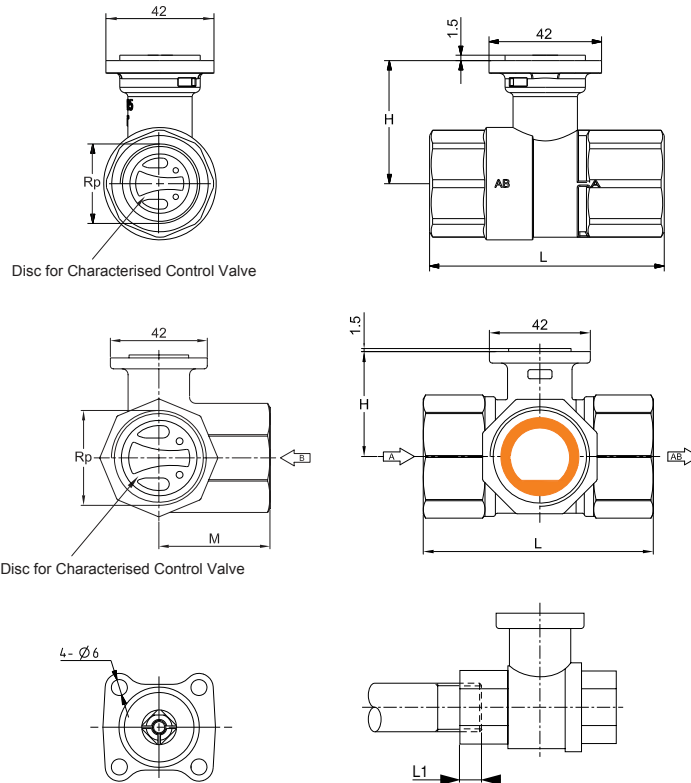

L1: Maximum screwing depth.
The actuator dimensions can be found on the respective actuator data sheet.

Type	Valve []	DN []	Rp ["]	L [mm]	L1 [mm]	H [mm]	M [mm]	Weight approx. [kg]
R2025-25-S2*	2-way	25	1	87	16	46	-	0.54
R2032-25-S3	2-way	32	1 1/4	105	19	50.5	-	0.77
R2050-58-S4	2-way	50	2	142	22	68	-	2.5
R2050-70-S4	2-way	50	2	142	22	68	-	2.5
R2065-150-S4	2-way	65	2 1/2	153	27	68	-	3.7
R2080-150-S4	2-way	80	3	160	30	68	-	4.1
R3032-25-S3	3-way	32	1 1/4	105	19	50.5	56	0.99
R3040-40-S4	3-way	40	1 1/2	122	19	62	66.5	1.8
R3050-58-S4	3-way	50	2	142	22	68	79	1.8

*no characterising disc for R2025-25-S2